

Series 1 Self-Service Bag Drop

The most cost effective entry level self-service bag drop



The Series 1 is an economical, easily deployable, retrofit model – integrated to the front of the existing check-in desk. The Series 1 Console is fitted with a hand-held scanner that enables passenger-operated bag tag scanning. The existing desks, conveyors and weigh scales are used, with the built-in ability to switch from self-service to agent-assisted modes of operation.

Features

- > Fits with / on to existing infrastructure
- > IATA CUSS platform
- > Highly configurable
- > No changes to BHS system
- > Overnight installation
- > Proven installed base
- > Simple user interface
- > Robust design
- > 1 or 2 step capable
- > Disability Access compliant
- > Upward compatible with ICM Series 3, 4 and 7 ABDs
- > < 30 seconds using the simple intuitive interface in a 2-step bag tagging process

Series 1 Self-Service Bag Drop

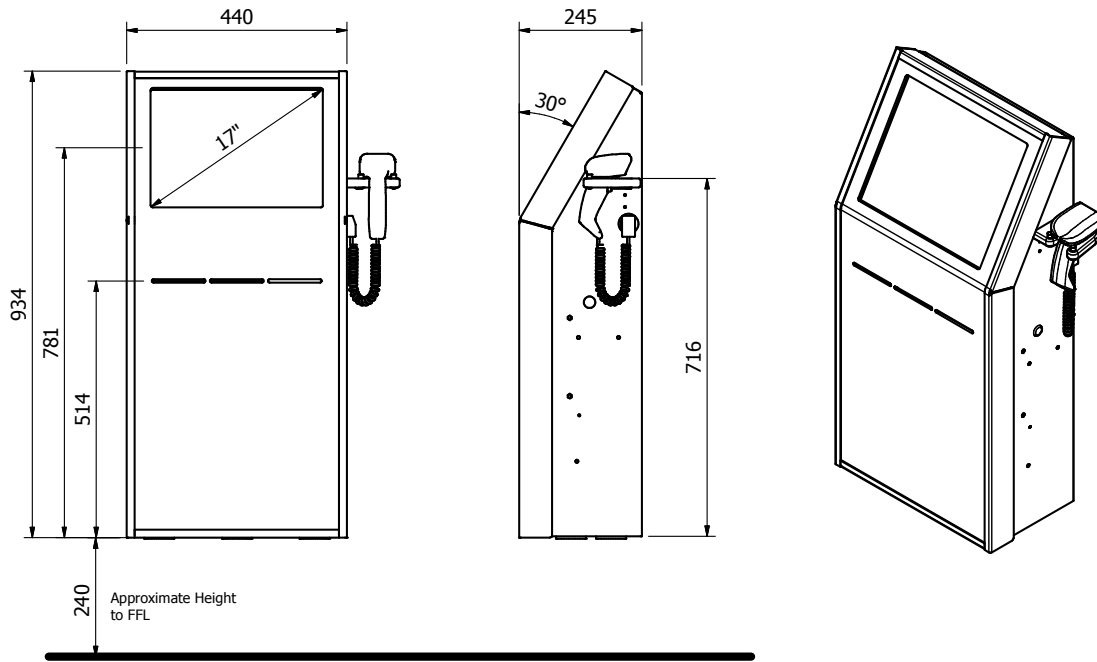

Features	Comments
Single Units	Left and Right handed versions available.
17" Capacitive Touch Screen	Responsive and generously sized for ease of use.
Hand-held Barcode Scanner	PAX operated for boarding pass and IATA bag tag scanning using a tethered, robust hand-held scanner.
CUSS Compliant	Centrally hosted (local or remote) web application supports a thin client architecture.
Customisable Hardware	Additional features such as biometric verification, passport validation, payment terminals, CCTV and RFID may be retro-fitted on to the Series 1.
Customisable Airline Application	ABD Airline Application design is configurable to client requirements. (Screen design, workflow sequence, animations, branding, etc.)
Local Process Rules	Flight table, baggage weight excess and other local rules can be easily configured by an authorised user.
Multi-lingual	Natively supports the use of multiple languages.
Fast Processing Time	< 30 seconds using the simple intuitive interface in a 2-step bag tagging process.
Receipt Printer	Baggage receipt printing per transaction (multiple bags on the same receipt). Facilitates excess baggage revenue collection by printing excess payment advice.
Heavy Tag / Bag Tag Printer	Up to 3 printers may be installed, accommodating a 1 or 2-step process.

*Please note that these features can be changed at any time by ICM without notice.

