

Series 1 Type 1 Self-Service Bag Drop



The most cost effective entry level self-service bag drop

The Series 1 Type 1 is an economical, easily deployable, retrofit model – integrated to the front of the existing check-in desk. The console is fitted with a hand-held scanner that enables passenger-operated bag tag scanning. The existing desks, conveyors and weigh scales are used, with the built-in ability to switch from self-service to agent modes of operation.

Features

- Fits with / onto existing infrastructure
- ICM's IATA certified CUSS platform
- Highly configurable
- No changes to BHS system
- Overnight installation
- Proven installed base
- Simple user interface
- Robust design
- 1 or 2 step capable
- Disability access compliant
- Upward compatible with ICM Series 3 ABD
- < 30 seconds using the simple intuitive interface in a 2-step bag tagging process

Series 1 Type 1 Self-Service Bag Drop

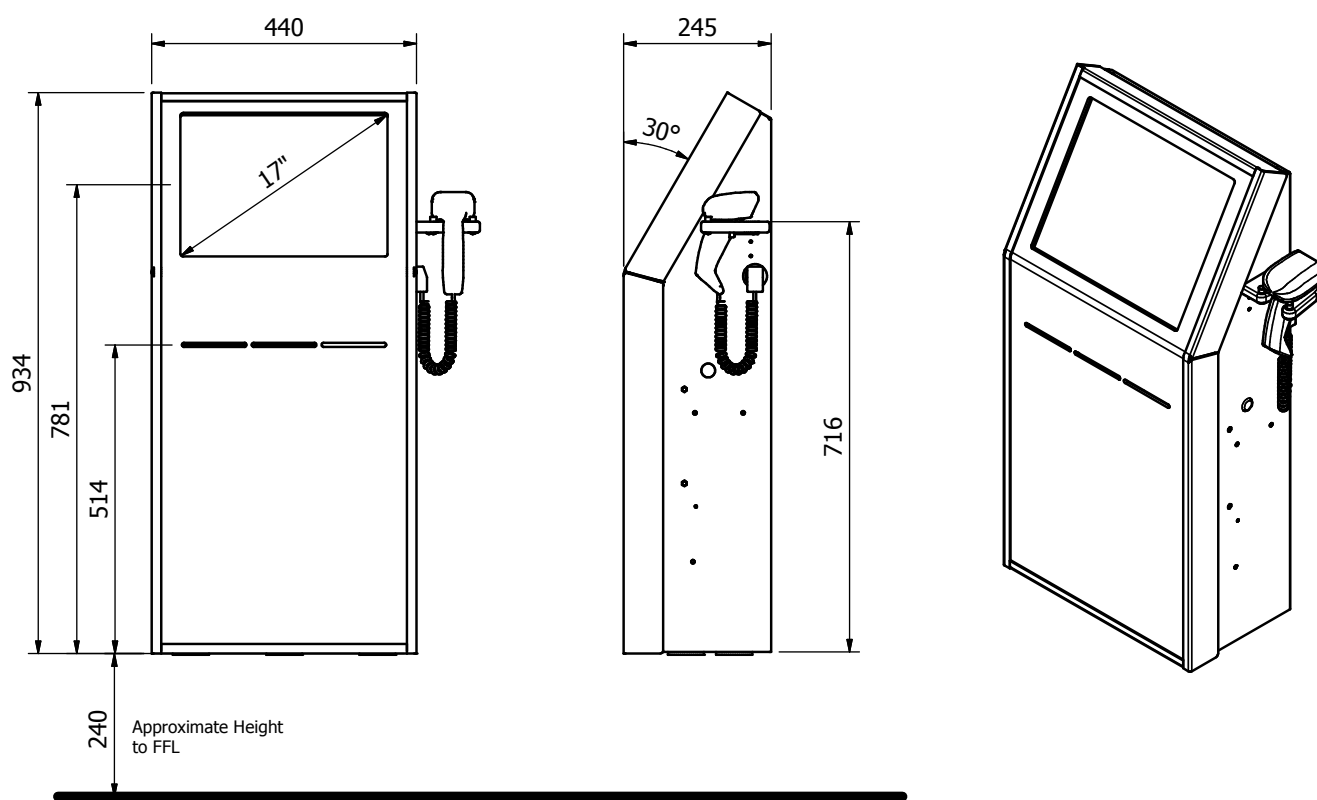

Product Specifications

| | |
|----------------------------------|---|
| Single Units | Left and right handed versions available. |
| 17" Capacitive Touch Screen | Responsive and generously sized for ease of use. |
| Hand-held Barcode Scanner | PAX operated for boarding pass and IATA bag tag scanning using a tethered, robust hand-held scanner. |
| CUSS Compliant | Centrally hosted (local or remote) web application supports a thin client architecture. |
| Customisable Hardware | Additional features such as biometric verification, passport validation, payment terminals, CCTV and RFID may be retro-fitted onto the Series 1 Type 1. |
| Customisable Airline Application | ABD Airline Application design is configurable to client requirements. (Screen design, workflow sequence, animations, branding, etc.) |
| Local Process Rules | Flight table, baggage weight excess and other local rules can be easily configured by an authorised user. |
| Multi-lingual | Natively supports the use of multiple languages. |
| Fast Processing Time | < 30 seconds using the simple intuitive interface in a 2-step bag tagging process. |
| Receipt Printer | Baggage receipt printing per transaction (multiple bags on the same receipt). Facilitates excess baggage revenue collection by printing excess payment advice. |
| Heavy Tag / Bag Tag Printer | Up to 3 printers may be installed, accommodating a 1 or 2-step process. |

*Please note that these features can be changed at any time by ICM without notice.