

# Series 1 Type 2 Self-Service Bag Drop



## The premium retrofit self-service bag drop

The Series 1 Type 2 is the premium retrofit bag drop solution – with an integrated console design for optional features such as biometric verification, passport validation, payment terminal, disability navigation panel amongst many others.

Multi-coloured lighting indicators attract and guide the passenger's attention. Lighting can easily be configured to match the existing airport design.

Each unit is fitted with printers and a hand-held scanner, enabling passenger-operated bag tag scanning. The unit is mounted to the front of the existing check-in desks, interfacing with the existing conveyors and weigh scales, with the built-in ability to switch from self-service to agent mode.

### Features

- Fits with / onto existing infrastructure
- ICM's IATA certified CUSS platform
- No changes to BHS system
- Sophisticated integrated design
- 1 or 2 step capable
- Disability access compliant
- Multi-lingual
- < 30 seconds transaction times using the simple intuitive interface in a 2-step bag tagging process
- Customisable airline application
- Adheres to local process rules
- Upward compatible with ICM Series 3 Type 2 ABD
- Optional features: Biometrics (face, fingerprint, iris, etc), e-Passport reader, payment terminal, disability navigation panel, audio socket and audible loudspeaker.

# Series 1 Type 2 Self-Service Bag Drop

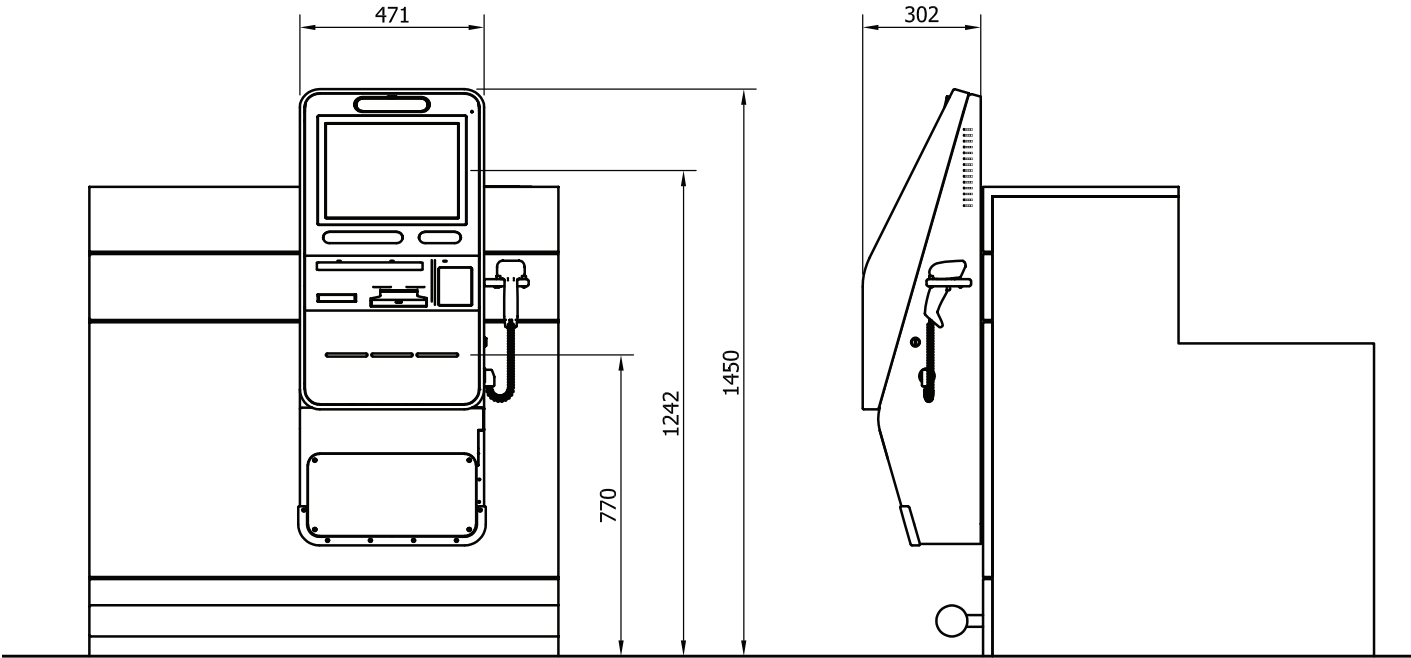

## Features



\*Please note that these features can be changed at any time by ICM without notice.